



조합식계량기

MULTIHEAD WEIGHER



● 자동포장시스템 통합솔루션

주식회사 이지시스템은 자동계량포장시스템을 전문으로 구축하는 회사입니다. 자동계량포장시스템에 대한 기획, 설계, 제작, 설치, 운영에 대한 토털 엔지니어링업체로서 프로젝트를 통합관리하고 원가절감, 공기단축, 품질 및 생산성 향상을 고객에게 제공합니다. 이를 위해 다양한 방면의 전문 기술인력을 보유하고 있으며 풍부한 경험과 지식을 바탕으로 고객만족과 성공적인 프로젝트의 완수를 위하여 항상 최선의 노력을 경주하고 있습니다.

EZ System regards itself as a best solution provider for weighing and packaging system in the food industry. Thanks to our accumulated experience and technologies, we have constructed state-of-the-art packaging facilities with the newest automation system. We formulate and propose systems that integrate all of the relevant processes that include conveying, weighing, packaging, checking and cartoning. By providing such solutions, we help raise efficiency of packaging processes, leading to lower costs and shorter delivery times. We are fully equipped to offer comprehensive solutions, from machinery selection to product development, in response to the diversified needs of customers. In EZ System, you can find a total packaging solution.



박스제함기, 박스포장기

CASE ERECTOR, CASE SEALER

We are able to select and systemize the most appropriate equipment.

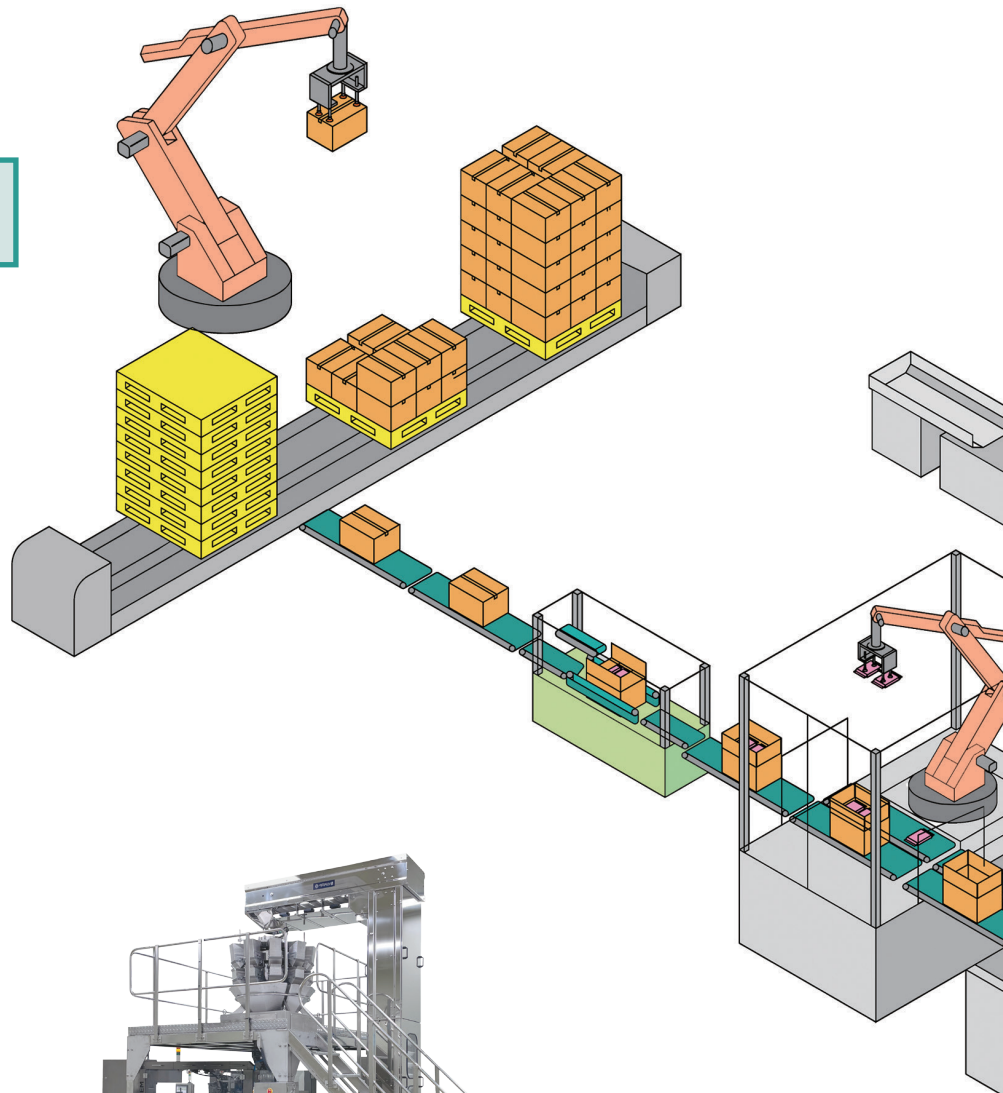

INTEGRATED PACKAGING SOLUTION

계량 Weighing

조합식계량기, 분체충전기, 액상충전기

MULTIHEAD WEIGHER, AUGER FILLER, LIQUID FILLER
We select optimal weighing and filling machines according to the contents to be packaged.



포장 Packaging

로타리자동포장기, 수직형자동포장기

ROTARY FILL-SEAL MACHINE
VERTICAL FORM-FILL-SEAL MACHINE
We select the best possible models from a broad lineup of automatic packaging machines.

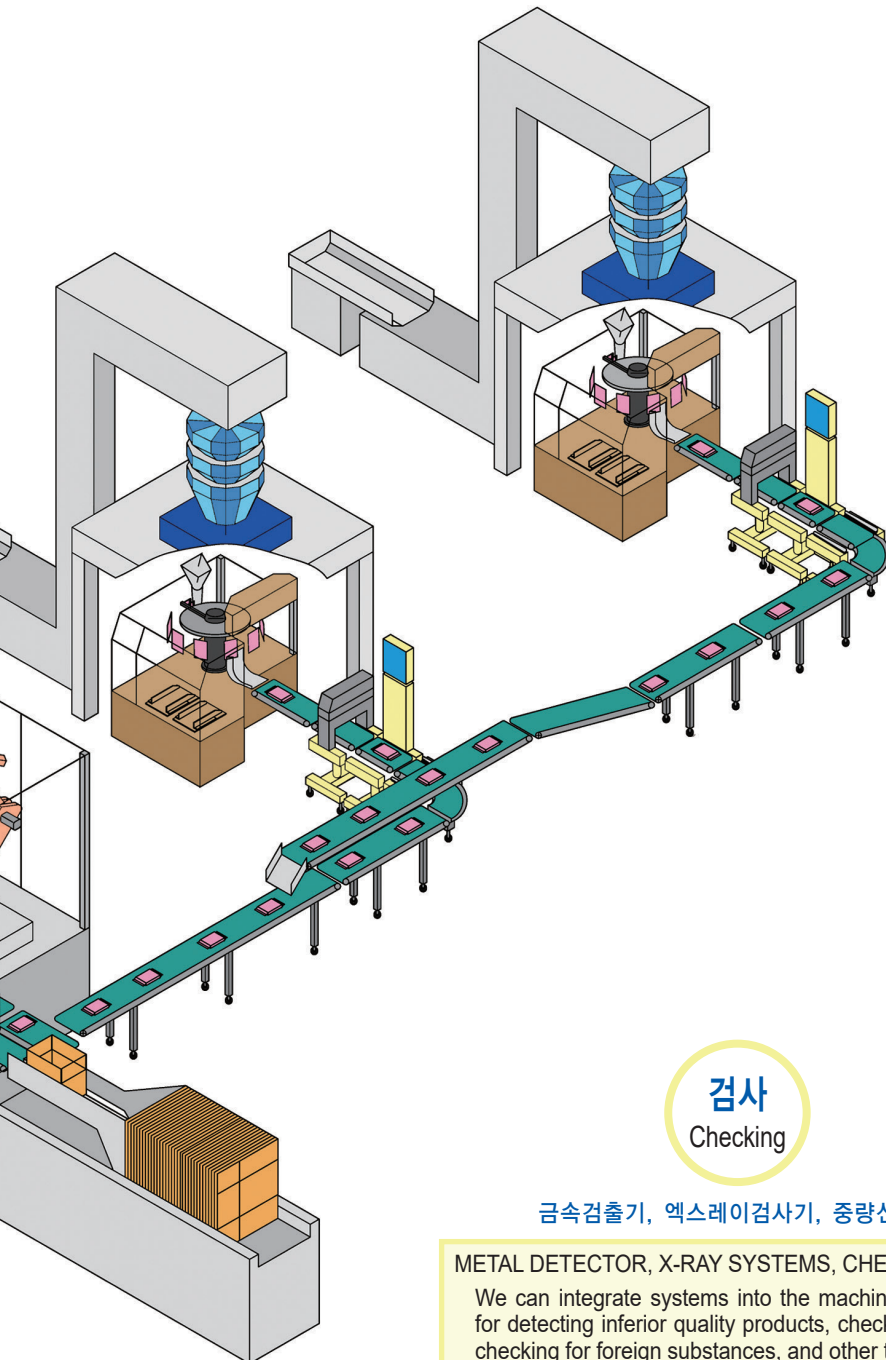

검사 Checking

금속검출기, 엑스레이검사기, 중량선별기

METAL DETECTOR, X-RAY SYSTEMS, CHECKWEIGHER
We can integrate systems into the machines required for detecting inferior quality products, checking weight, checking for foreign substances, and other tasks.



● 조합식계량기

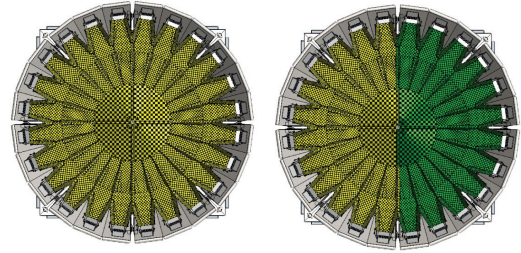
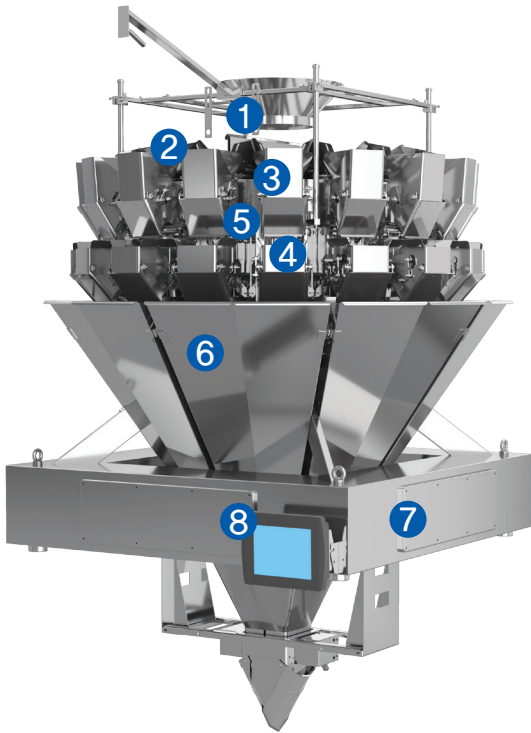

1종 배출 1Product

2종 배출 2MIX

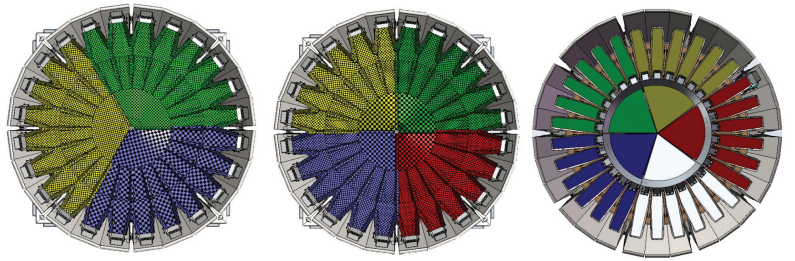

3종 배출 3MIX

4종 배출 4MIX

5종 배출 5MIX

<p>① 방사피더 Top Cone</p>	<ul style="list-style-type: none"> 공급장치로부터 이송된 제품이 조합식계량기 방사피더로 공급됩니다. The product is fed to the top cone by a feeding system designed for the product's particular.
<p>② 직진피더 Linear Feeder Pan</p>	<ul style="list-style-type: none"> 직진피더의 진동에 의해 제품이 균일하게 이송버킷으로 투입됩니다. 직진피더의 진동세기 및 동작시간을 조절할 수 있습니다. Feeds the product evenly into feed buckets.
<p>③ 이송버킷 Feed Bucket</p>	<ul style="list-style-type: none"> 제품이 직진피더로부터 이송버킷으로 투입됩니다. 모서리가 라운드 처리되어 있어 청소가 용이하고 제품이 끼는 것을 방지합니다. 제품 특성에 맞는 다양한 용량의 버킷이 있습니다.(0.5L ~ 5.5L) From the linear feeder pans the product is discharged into the feed buckets. Has large-radius corners and is easy to clean reducing downtime. It is hard to stick the tiny products on the bucket corners. Buckets are available in several sizes and specialized designs.(0.5L to 5.5L)
<p>④ 계량버킷 Weigh Bucket</p>	<ul style="list-style-type: none"> 제품이 이송버킷으로부터 계량버킷으로 투입됩니다. 마이크로프로세서의 고속연산을 통해 최대 210회/분의 속도로 제품을 계량합니다. 모서리가 라운드 처리되어 있어 청소가 용이하고 제품이 끼는 것을 방지합니다. 제품 특성에 맞는 다양한 용량의 버킷이 있습니다.(0.5L ~ 5.5L) The product is recorded as partial portions. The computer will empty the most suitable weighing buckets for obtaining accurate portion weight. Has large-radius corners and is easy to clean reducing downtime. It is hard to stick the tiny products on the bucket corners. Buckets are available in several sizes and specialized designs.(0.5L to 5.5L)
<p>⑤ 구동모듈 Actuator Modules</p>	<ul style="list-style-type: none"> 내구성이 충분하고 수명이 긴 로드셀과 스텝모터 등이 장착되어 있습니다. Self-contained and long-life load cell and stepping motors.
<p>⑥ 집합슈트 Collating Chute</p>	<ul style="list-style-type: none"> 목표중량으로 계량된 제품이 계량버킷으로부터 집합슈트를 따라 배출됩니다. Those partial portions which together come closest to the target weight are dropped from the weigh buckets and slide down through the collating chute.
<p>⑦ 베이스프레임 Base Frame</p>	<ul style="list-style-type: none"> 최신 기술의 컨트롤 시스템이 내장되어 있습니다. The control system is state-of-the-art technology for high output, flexibility and accuracy.
<p>⑧ 컬러터치스크린 Touch Screen</p>	<ul style="list-style-type: none"> 터치스크린을 통해 조합식계량기를 쉽게 조작할 수 있습니다. Uses easy-to-understand graphics in a simple and straightforward way to make training quick and operating easy.



MULTIHEAD WEIGHER

특 징

· 고속 · 고정밀도 계량

최신 기술의 마이크로프로세서에 의한 디지털 제어방식으로 더욱 빠르고 정확하게 제품을 계량합니다. 고강도 로드셀의 사용으로 중량 측정시간을 현저히 단축시켜 고정밀도의 계량이 가능합니다. 새로운 기술의 필터를 사용하여 초고속 계량을 실현합니다.

· 위생적인 구조 · 청소의 용이

모든 제품접촉부(방사피더, 직진피더, 이송버킷, 계량버킷, 슈트 등)는 스테인리스 스틸로 되어 있어 아주 위생적이고 내구성이 뛰어납니다. 제품접촉부가 공구를 사용하지 않고 쉽게 분리되어 청소가 용이합니다.

· 간단한 작동방법

컬러터치스크린의 채택으로 계량기를 쉽게 조작할 수 있으며, 스크린을 통해 오류진단이 가능합니다.

· 조용한 작업환경

스텝모터를 통해 버킷의 개폐속도를 조절할 수 있어 제품 특성에 맞는 최적의 계량속도를 구현합니다. 또한 직진피더가 소음을 최소화시키는 구조로 되어 있어 조용한 작업환경을 제공합니다.

· 데이터 관리 및 컴퓨터 네트워크(선택사양)

99품종의 계량조건을 저장할 수 있으며 통계 기능을 통해 계량데이터, 집계데이터, 이력데이터를 관리할 수 있습니다. 컴퓨터와 연결하여 네트워크를 구축할 수 있습니다.

- 바이브레이터 방식의 제품 이송으로 제품의 손상이 거의 없습니다.
- 계량기 동작중의 자동영점조정을 통해 고정밀의 계량이 가능합니다.
- 다중배출 기능이 있어 가볍고 부피가 큰 제품의 계량도 가능합니다.
- 순차배출 기능이 있어 부피가 큰 제품도 포장용기에 막힘이 없이 계량이 가능합니다.
- 어떠한 종류의 자동포장기와도 쉽게 연동이 가능하여 생산성을 극대화할 수 있습니다.

COMMON FEATURES

- The multihead weigher, available in 10, 14, 16, 18, 20 and 24 head configuration, weighs products efficiently and accurately at high speeds and has been designed to handle almost any type of food product as well as non food applications.
- The strain gauge load cells are automatically calibrated during operation at predetermined intervals by using internal precise calibration weights, thereby guaranteeing the highest accuracy and availability.
- Easy operation via color touch screen to make operation, trouble shooting and recovery easy to learn and simple to use.
- Top cone, linear feeder pans, feed buckets, weigh buckets and collating chute are made of stainless steel(304SS). Surfaces and geometries of all product leading parts are adapted to meet specific product/application requirements.
- The weighers use accurate and repeatable stepping motors for bucket door actuation. Motor patterns are adjustable and programmable to ensure the highest speed and efficiency for a wide variety of products.
- Automatic load cell spanning and calibration using certified integrated calibration weight.
- Product-specific surfaces of all product contact parts - perfectly matched to unique product.
- Through the use of modular actuators, easy-to-use operator interfaces and easy maintenance, our weighers provide maximum up-time.
- Available various models with different bucket configuration.(0.5 to 5.5L)
- Precise weighing accuracy and high speed.
- Minimum product giveaway.
- Tool-less disassembly for quick wash-out.
- Multi-dump function to achieve higher target weights.
- Staggered discharge to avoid big pieces blocked.
- Easily interfaced with any type of packaging machine for full automation.
- Stores 99 programs in memory.

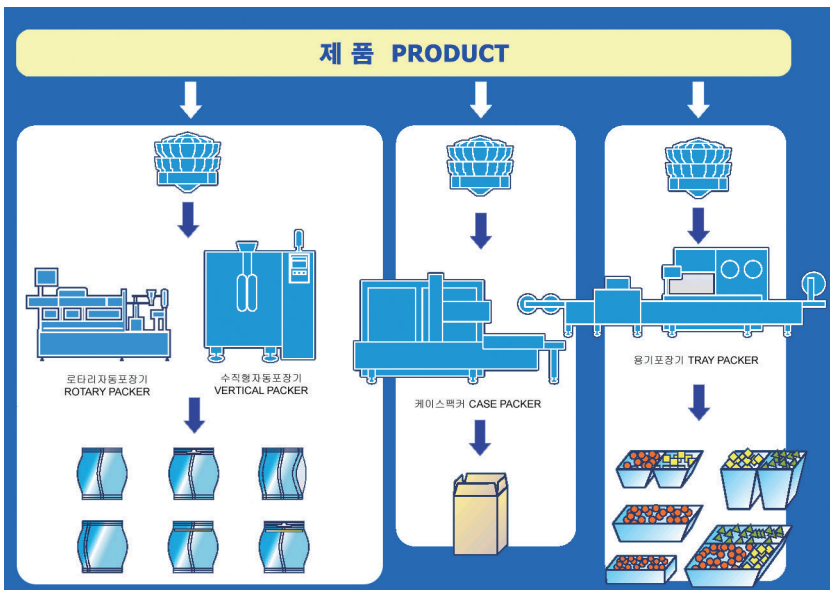

적 용

- 냉동식품
- 가공식품
- 스낵류
- 캔디류
- 농산물
- 해산물
- 공업제품

APPLICATIONS

- Dry foods
- Processed foods
- Frozen foods
- Fresh foods
- Snack
- Seeds
- Candies
- Nuts
- Coffee
- Beans
- Pasta
- Pet foods
- Pharmaceuticals
- Hardware

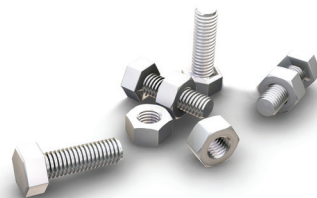
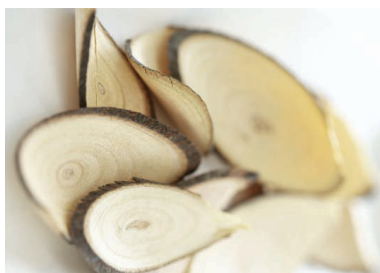

● 조합식계량기

B SERIES

Cost-Effective

- 10/14/20 헤드로 구성된 Basic 계량기입니다.
- 보편적이고 일반적인 기종입니다.
- 싱글플랩/트윈플랩 방식으로 버킷이 개방되어 제품 계량을 용이하게 합니다.
- 견고한 디자인과 구조로 제작되었습니다.
- 스테인리스 스틸 구조로 제작되었습니다.

- The 10, 14, 20 heads weigher weighs products efficiently and accurate at high speed.
- 4.0 generation modular control system.
- The single flap and twin flap opening system guarantees a complete discharge even of difficult and sticky product.
- Robust design and construction.
- Full stainless steel machine.



CS-1016F-4GB

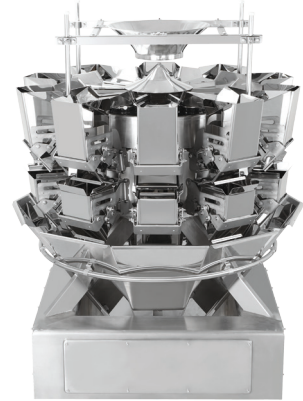

CS-1430F-4GB

P SERIES

High Speed Application

- 10/14/20 헤드로 구성된 Plus 모델의 계량기입니다.
- 빠르고 정밀함을 결합한 세계적 수준의 계량기입니다.
- 싱글플랩/트윈플랩 방식으로 버킷이 개방되어 제품 계량을 용이하게 합니다.
- 3D 메뉴 모니터로 더 쉽고 간단한 조작이 가능합니다.
- 스테인리스 스틸 구조로 제작되었습니다.
- 카메라가 부착되어 있어 계량동작 상황을 모니터 화면을 통해 볼 수 있습니다.(선택사양)
- USB를 통해 프로그램 저장 및 업그레이드가 가능합니다.
- 유무선 네트워크 기능을 탑재하여 컴퓨터를 통해 원격 제어가 가능합니다.

- The 10, 14, 20 heads weigher weighs products efficiently and accurate at high speed and has been designed to handle almost any types of food products as well as non food applications.
- World-class multihead weigher combine fast and accurate weighing.
- The single flap and twin flap opening system guarantees a complete discharge even of difficult and sticky product.
- 3D menu monitor with smarter functions achieve easier and simpler operation.
- 4.0 generation modular control system.
- Full stainless steel machine.
- Software and mechanic improvements achieve top performance in the industry.



CS-1016F-4GP

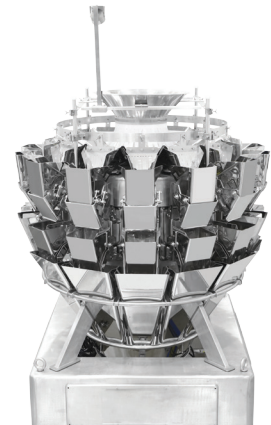

CS-1430F-4GP

CS-1016-4GB

CS-1430-4GB

CS-1016-4GP

CS-1430-4GP

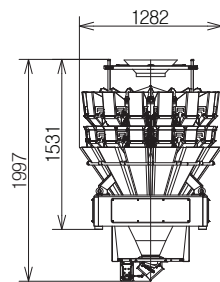
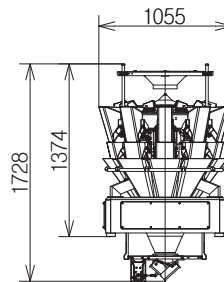
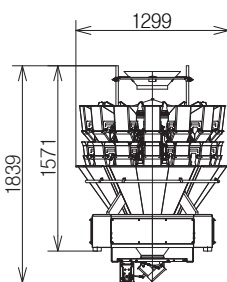
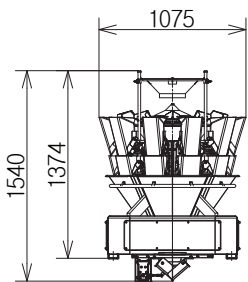

※ 집합버킷은 선택사양임. Collection bucket is optional.

※ Drawing dimensions are not to scale and are approximate.

MULTIHEAD WEIGHER

● 사양 TECHNICAL DETAILS

B SERIES						
MODEL	CS-1016-4GB	CS-1030-4GB	CS-1416-4GB	CS-1430-4GB	CS-2016-4GB	CS-2030-4GB
계량속도(Max.)* Weighing speed	70 WPM	70 WPM	120 WPM	120WPM	60/120 WPM	60/120 WPM
계량정밀도(Max.)** Weighing accuracy	±0.5g ~ ±2g	±0.5g ~ ±2g	±0.5g ~ ±2g	±0.5g ~ ±2g	±0.5g ~ ±2g	±0.5g ~ ±2g
계량범위 Target weight range	20g ~ 2000g	20g ~ 2000g	20g ~ 2000g	20g ~ 2000g	20g ~ 2000g	20g ~ 2000g
중량표시 Minimum graduation	0.1g	0.1g	0.1g	0.1g	0.1g	0.1g
SPECIFICATIONS						
계량조 Heads	10	10	14	14	20	20
버킷용량 Bucket Sizes	1.6L	3L	1.6L	3L	1.6L	3L
버킷형태 Bucket type	Single open	Double open	Single open	Double open	Single open	Double open
배출구 Mix & split options	1, 2					
컨트롤 Control system	4.0G Basic					
네트워크 PC connection	-					
버킷구동 Bucket actuator	Stepping motor					
터치스크린 Touch screen display	10.4" Color LCD display					
저장능력 Number of presets	99					
로드셀 Weigh cell	Strain gauge loadcell					
재질 Materials	Surfaces : 304 stainless steel, Other : sanitary materials					
전기 Power	220V 50/60Hz 1-phase					
선택사양 Options	Various options are available					

상기 사양은 성능 향상을 위해 예고 없이 변경될 수 있습니다. Specifications are subject to change without prior notice.

* 제품의 크기 및 물성, 목표 중량 등에 따라 변동될 수 있습니다. Depends on product shape and density, target weight, feeding conditions.

** 제품의 크기 및 물성, 목표 중량, 설정 속도 등에 따라 변동될 수 있습니다. Depends on product shape and density, target weight and target speeds.

P SERIES						
MODEL	CS-1016-4GP	CS-1030-4GP	CS-1416-4GP	CS-1430-4GP	CS-2016-4GP	CS-2030-4GP
계량속도(Max.)* Weighing speed	80 WPM	80 WPM	130 WPM	130WPM	65/130 WPM	65/130 WPM
계량정밀도(Max.)** Weighing accuracy	±0.5g ~ ±2g	±0.5g ~ ±2g	±0.5g ~ ±2g	±0.5g ~ ±2g	±0.5g ~ ±2g	±0.5g ~ ±2g
계량범위 Target weight range	20g ~ 2000g	20g ~ 2000g	20g ~ 2000g	20g ~ 2000g	20g ~ 2000g	20g ~ 2000g
중량표시 Minimum graduation	0.1g	0.1g	0.1g	0.1g	0.1g	0.1g
SPECIFICATIONS						
계량조 Heads	10	10	14	14	20	20
버킷용량 Bucket Sizes	1.6L	3L	1.6L	3L	1.6L	1.6L
버킷형태 Bucket type	Single open	Double open	Single open	Double open	Single open	Double open
배출구 Mix & split options	1, 2					
컨트롤 Control system	4.0G Plus					
네트워크 PC connection	CAN bus					
버킷구동 Bucket actuator	Stepping motor					
터치스크린 Touch screen display	10.4" Color LCD display					
저장능력 Number of presets	99					
로드셀 Weigh cell	Strain gauge loadcell					
재질 Materials	Surfaces : 304 stainless steel, Other : sanitary materials					
전기 Power	220V 50/60Hz 1-phase					
선택사양 Options	Various options are available					

상기 사양은 성능 향상을 위해 예고 없이 변경될 수 있습니다. Specifications are subject to change without prior notice.

* 제품의 크기 및 물성, 목표 중량 등에 따라 변동될 수 있습니다. Depends on product shape and density, target weight, feeding conditions.

** 제품의 크기 및 물성, 목표 중량, 설정 속도 등에 따라 변동될 수 있습니다. Depends on product shape and density, target weight and target speeds.

● 적용 APPLICATIONS

냉동식품, 가공식품, 스낵류, 캔디류, 농산물,
해산물, 공업제품

Dry foods, Processed foods, Frozen foods, Fresh foods, Snack, Seeds,
Candies, Nuts, Coffee, Beans, Pasta, Pet foods, Pharmaceuticals, Hardware



● 조합식계량기

C SERIES

- 채소나 과일 등의 종자나 작고 가벼운 제품의 소량 중량을 빠르고 정밀하게 계량합니다.
- 본체가 콤팩트한 구조로 되어 있어 좁은 공간에서도 설치가 가능합니다.
- Small bucket multihead weigher.
- For small items such as vegetable seeds and fruit seeds.
- The compact design offers high accuracy on small target weight.
- The small size configuration reduces the height of the weigher which saves the space a lot.
- Soft handling design for fragile products by reducing the falling distance.

Small Target Weight



CS-1008-4GB



CS-1405-4GB

LV SERIES

- 셸러드와 같이 부피가 큰 제품 계량에 적합한 계량기입니다.
- 버킷용량이 5.5L, 7.5L 2종류(택일)가 있어 다양한 제품을 적용시킬 수 있습니다.
- 카메라(선택사양)가 부착되어 있어 계량동작 상황을 모니터 화면을 통해 볼 수 있습니다.
- 유무선 네트워크 기능을 탑재하여 컴퓨터를 통해 원격 제어가 가능합니다.(모델별 사양 확인)
- USB를 통해 프로그램 저장 및 업그레이드가 가능합니다.
- Big bucket weigher is suitable for weighing bulky products.
- There are two types of bucket capacity (5.5L and 7.5L), so you can apply various products.
- The top cone rotates to evenly distribute the product.
- Software and mechanic improvements achieve top performance in the industry.

Bulky Products



CS-1455BB-4GP



CS-1655BB-4GP

L SERIES

- 원형식 계량기에서 계량이 어려운 점착물 제품이나 신선식품 계량에 적합한 계량기입니다.
- 슬라이딩 방식의 버킷이 부착되어 있어 버킷 내부에 잔여물이 거의 남지 않아 계량정밀도가 향상됩니다.
- 플라스틱 버킷 내면은 줄무늬로 되어 있어 있습니다.
- 물청소가 가능한 위생적인 구조로 되어 있습니다.
- 모든 제품 접촉부는 공구 없이 탈착이 가능합니다.
- It is suitable for weighing sticky and fresh products.
- Hoppers with scraper doors to force sticky products down.
- 3-level hoppers including memory hoppers to increase speed and accuracy.
- Water cleaning is possible.
- All product contacts are removable without tools.

High Sticky Products and Fresh Foods



CS-0615M-4GP



CS-0815M-4GP

MULTIHEAD WEIGHER

● 사양 TECHNICAL DETAILS

C SERIES			
MODEL	CS-1008-4GB	CS-1405-4GB	CS-1401-4GP
계량속도(Max.)* Weighing speed	70 WPM	120 WPM	120 WPM
계량정밀도(Max.)** Weighing accuracy	±0.1g ~ ±1g	±0.1g ~ ±1g	±0.03g
계량범위 Target weight range	2g ~ 300g	2g ~ 300g	0.5g ~ 50g
중량표시 Minimum graduation	0.1g, 0.01g	0.1g, 0.01g	0.1g, 0.01g
SPECIFICATIONS			
계량조 Heads	10	14	14
버킷용량 Bucket Sizes	0.8L	0.5L	0.1L
버킷형태 Bucket type	Double open	Double open	Single open
배출구 Mix & split options	1, 2		
컨트롤 Control system	4.0G Basic		4.0G Plus
네트워크 PC connection	-	-	CAN bus
버킷구동 Bucket actuator	Stepping motor		
터치스크린 Touch screen display	10.4" Color LCD		
저장능력 Number of presets	99		
로드셀 Weigh cell	Strain gauge loadcell		
재질 Materials	Surfaces : 304 stainless steel, Other : sanitary materials		
전기 Power	220V 50/60Hz 1-phase		
선택사양 Options	Various options are available		

LV SERIES					
MODEL	CS-1055-4GB CS-1075-4GB	CS-1055-4GP CS-1075-4GP	CS-1455-4GB CS-1475-4GB	CS-1455-4GP CS-1475-4GP	CS-1655-4GP CS-1675-4GP
계량속도(Max.)* Weighing speed	50 WPM	60 WPM	70 WPM	80 WPM	100 WPM
계량정밀도(Max.)** Weighing accuracy	±2g ~ ±4g	±2g ~ ±4g	±2g ~ ±4g	±2g ~ ±4g	±2g ~ ±4g
계량범위 Target weight range	25 ~ 5000g	25 ~ 5000g	25 ~ 5000g	25 ~ 5000g	25 ~ 5000g
중량표시 Minimum graduation	0.1g	0.1g	0.1g	0.1g	0.1g
SPECIFICATIONS					
계량조 Heads	14	10	14	14	16
버킷용량 Bucket Sizes	5.5 / 7.5L	5.5 / 7.5L	5.5 / 7.5L	5.5 / 7.5L	5.5 / 7.5L
버킷형태 Bucket type	Double open	Double open	Double open	Double open	Double open
배출구 Mix & split options	1, 2				
컨트롤 Control system	4.0G Basic, 4.0G Plus				4.0G Plus
네트워크 PC connection	-	CAN bus	-	CAN bus	CAN bus
버킷구동 Bucket actuator	Stepping motor				
터치스크린 Touch screen display	10.4" Color LCD				
저장능력 Number of presets	99				
로드셀 Weigh cell	Strain gauge loadcell				
재질 Materials	Surfaces : 304 stainless steel, Other : sanitary materials				
전기 Power	220V 50/60Hz 1-phase				
선택사양 Options	Various options are available				

L SERIES			
MODEL	CS-0615M-4GP	CS-0815M-4GP	CS-1015M-4GP
계량속도(Max.)* Weighing speed	40 WPM	60 WPM	80 WPM
계량정밀도(Max.)** Weighing accuracy	±0.5g ~ ±2g	±0.5g ~ ±2g	±0.5g ~ ±2g
계량범위 Target weight range	2g ~ 300g	2g ~ 300g	0.5g ~ 50g
중량표시 Minimum graduation	0.1g	0.1g	0.1g
SPECIFICATIONS			
계량조 Heads	6	8	10
버킷용량 Bucket Sizes	1.5L	1.5L	1.5L
버킷형태 Bucket type	Scraping bucket	Scraping bucket	Scraping bucket
배출구 Mix & split options	1, 2		
컨트롤 Control system	4.0G Plus		
네트워크 PC connection	CAN bus		
버킷구동 Bucket actuator	Stepping motor		
터치스크린 Touch screen display	10.4" Color LCD		
저장능력 Number of presets	99		
로드셀 Weigh cell	Strain gauge loadcell		
재질 Materials	Surfaces : 304 stainless steel, Other : sanitary materials		
전기 Power	220V 50/60Hz 1-phase		
선택사양 Options	Various options are available		

상기 사양은 성능 향상을 위해 예고 없이 변경될 수 있습니다. Specifications are subject to change without prior notice.

* 제품의 크기 및 물성, 목표 중량 등에 따라 변동될 수 있습니다. Depends on product shape and density, target weight, feeding conditions.

** 제품의 크기 및 물성, 목표 중량, 설정 속도 등에 따라 변동될 수 있습니다. Depends on product shape and density, target weight and target speeds.

● 자동계량포장시스템

Optimal Weighing and Packaging Solutions

자동계량포장시스템 COMBI SYSTEM

- 조합식계량기 • 급대식 로타리자동포장기 • 버켓엘리베이터 • Multihead Weigher • Rotary Fill-Seal Machine • Bucket Elevator

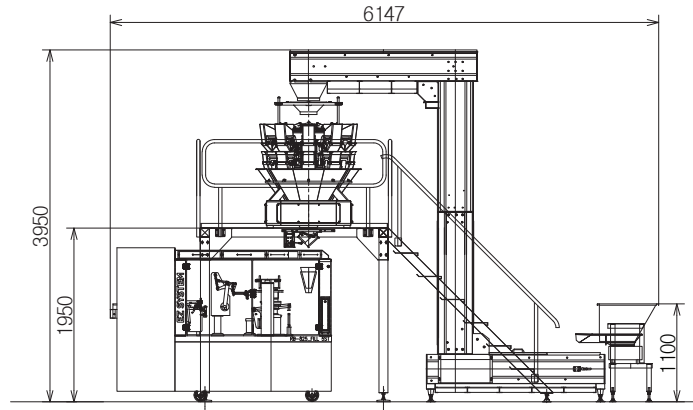

자동계량포장시스템 COMBI SYSTEM

- 조합식계량기 • 급대식 로타리자동포장기 • 경사컨베이어 • Multihead Weigher • Rotary Fill-Seal Machine • Inclined Conveyor

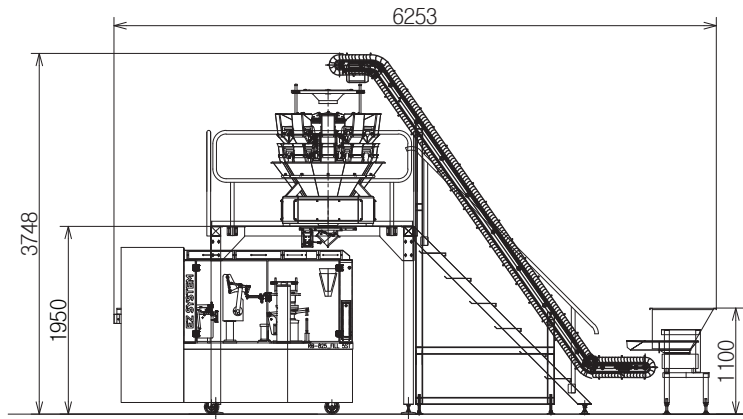

자동계량포장시스템 COMBI SYSTEM

- 조합식계량기(트윈타입) • 급대식 로타리자동포장기 • Multihead Weigher(Twin Type) • Rotary Fill-Seal Machine

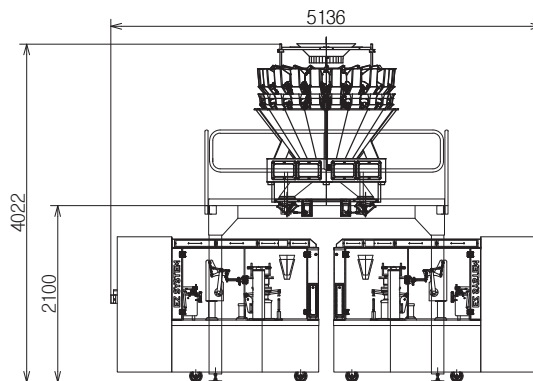

PACKAGING SYSTEM

Inspection System and Conveyor

금속검출기

Metal Detector



중량선별기

Checkweigher



버킷엘리베이터

Bucket Elevator



경사컨베이어

Inclined Conveyor



경사컨베이어

Inclined Conveyor



컵 컨베이어

Cup Conveyor



바이브로피더&호퍼

Vibrofeeder&Hopper



계량기용데크

Platform



턴테이블

Turn Table



“The Best Solution Provider of Multihead Weigher”

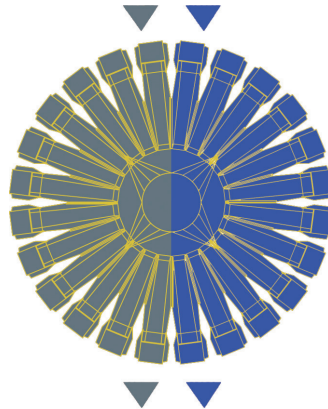

EZ SYSTEM

주식회사 이지시스템

인천광역시 서구 장고개로 243번길 19

Tel. 032-584-3330

Fax. 032-584-3329

E-mail : ezsystem21@naver.com

www.ezsystem21.com

EZ SYSTEMS CO., LTD

19, Janggogae-ro 243beon-gil, Seo-gu, Incheon, Korea

Tel. +82-32-584-3330

Fax. +82-32-584-3329

E-mail : ezsystem21@naver.com

www.ezsystem21.com